

BLAZE PRAKTIK COMBI

Combined boiler for wood and pellets



7 years warranty
on the boiler body



Automatic
control unit
ecoMAX



Online
management via
ecoNET

The boiler BLAZE PRAKTIK, which is supplemented with a rotary pellet burner. All the advantages of the BLAZE PRAKTIK boiler are retained and the combined boiler also offers the

possibility to burn wood pellets. The changeover to pellet combustion is automatic, thus ensuring continuous operation.

Benefits of BLAZE PRAKTIK COMBI

- All advantages of the BLAZE PRAKTIK boiler
- Rotary burner, maintenance-free operation
- Automatic changeover to pellet combustion
- Choice of pellet hopper type and and feeder length

More
info about
the boiler



Technical parameters

	BPC 25	BPC 40
Nominal output wood (kW)	25	40
Adjustable output wood (kW)	7–25	12–40
Adjustable output pellet (kW)	5–20	5–25
Wood/pellets efficiency (%)	93/94	94/94
Emission class	5	
Ecodesign	YES	
Energy class	A+	
Log length (cm)	33	50
Pellet diameter (mm)	6–8	
Stocking chamber volume (l)	80	120
Boiler weight (kg)	370	470
Maximum operating pressure (bar)	3	
Water compartment volume (l)	40	55
Hopper volume (l)	optional	

Dimensions

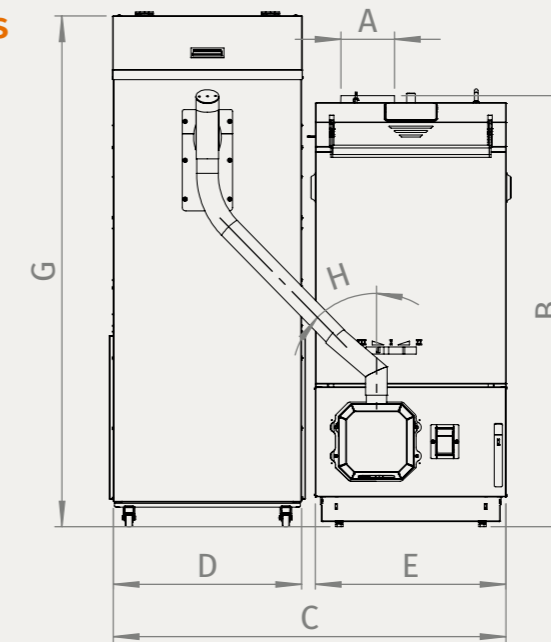

	BPC 25 (mm)	BPC 40 (mm)
A	Ø147	Ø147
B	1193	1193
C	1104	1288
D	544	544
E	530	714
F	1294	1294
G	1417	1417
H	45°	45°
I	G 6/4"	G 6/4"
J	G 1/2"	G 1/2"
K	956	956
L	937	937
M	367	367
N	127	127
O	127	127

